

Sanitary Reducing Valve

P130L,P130H,P130G, P130A,P130,P130C

SEALING SYSTEMS

DESCRIPTION

The **ADCA P-130** series direct acting, spring-loaded diaphragm sensing, pressure reducing valves are designed for use on compressed air, water and other gases or liquids compatible with the materials of construction.

MAIN FEATURES

1. Compact design
2. Completely machined from barstock material no castings or forgings are used on the standard version
3. No rising stem

STANDARD SURFACE FINISH

Internal wetted parts: <0.5 micron Ra
External wetted parts: ≤0.8 micron Ra
 (0.25 micron Ra and electro polished as option Ultrasonic cleaning)

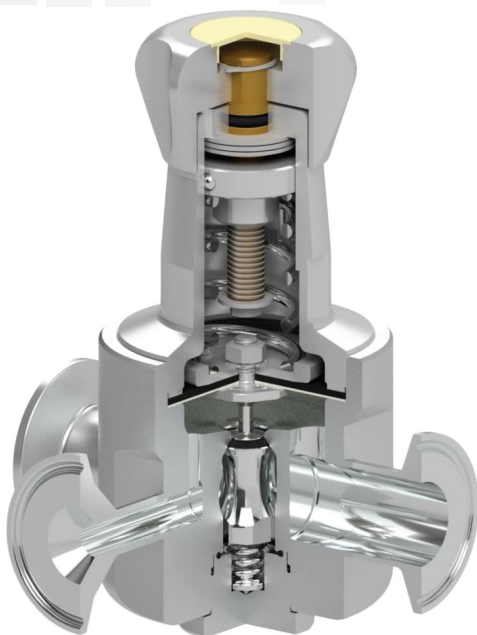

Cut away view with pressure gauge connection

OPTIONS: Self relieving, Leakage line connection 1/8" (captured vent), Panel mounting version (thread M45), Gauge connection on body, Different soft valves for liquids and gases, Special execution for steam

USE: Compressed air, water and other gases and liquids compatible with the construction

AVAILABLE MODELS: P-130

SIZES: DN1/2" to DN1", DN08 to DN25

SPRING RANGES: 0.2-1.5 bar, 0.3-3 bar, 0.8-8 bar

CONNECTIONS: Clamp ends or others on request

PACKAGING: Assembling and packaging in a clean room Certified according to ISO 14644-1, The product is end capped and vacuum sealed with recyclable plastic film to avoid contamination

INSTALLATION: Horizontal installation

ORDER REQUIREMENTS: Type of fluid
 Maximum operating temperature
 Inlet pressure and required outlet pressure, capacity (maximum and minimum)

LIMITING CONDITIONS	
Valve model	P-130
Body design conditions	PN 16
Max.upstream pressure	16 bar
Max.downstream pressure	8 bar
Min.downstream pressure	0.2 bar
Max.design temperature *	150 °C

*Other on request.

CE MARKING (PED - European Directive 97/23/EC)	
PN 16	Category
DN 1/2" to 1"	SEP - art. 3, paragraph3

DIMENSIONS (mm) ASME BPE

SIZE DN	KVs* m3/h	A**	B	C	D	d1	d2**	E	F	H	WGT. Kgs
1/2"	3	130	36,5	130	80	50,5	22,1	65	25	9,4	2,9
3/4"	3,2	130	36,5	130	80	50,5	22,1	67,5	25	15,75	2,9
1"	3,3	130	36,5	130	80	50,5	22,1	72,5	50,4	22,1	3,4

DIMENSIONS (mm) DIN

SIZE DN	KVs* m3/h	A**	B	C	D	d1	d2**	E	F	H	WGT. Kgs
10	3	120	36,5	130	80	50,5	22,1	65	34	10	2,9
15	3,2	120	36,5	130	80	50,5	22,1	67,5	34	16	3
20	3,3	120	36,5	130	80	50,5	22,1	67,5	34	20	3,1
25	3,5	120	38,5	128	80	50,5	22,1	72,5	50,5	26	3,4

Clamp ferrules DIN 32676 Series A Tube weld DIN 11866 Series A (DIN 11850 Series 2)

DIMENSIONS (mm) ISO

SIZE DN	KVs* m3/h	A**	B	C	D	d1	d2**	E	F	H	WGT. Kgs
8	3	120	36,5	130	80	50,5	22,1	65	25	10,3	2,9
10	3,2	120	36,5	130	80	50,5	22,1	67,5	25	14	3
15	3,3	120	36,5	130	80	50,5	22,1	67,5	50,5	18,1	3,2
20	3,5	120	38,5	128	80	50,5	22,1	72,5	50,5	23,7	3,4

Clamp ferrules DIN 32676 Series B; Tube weld DIN 11866 Series B (ISO 1127 Series 1)

* Reduced KVs on request.

** Special versions or non-standard sanitary clamp ferrules are available on request, both for the inlet/outlet and pressure gauge connection.

Valves with aluminium handwheel weights less 0,24 kgs.

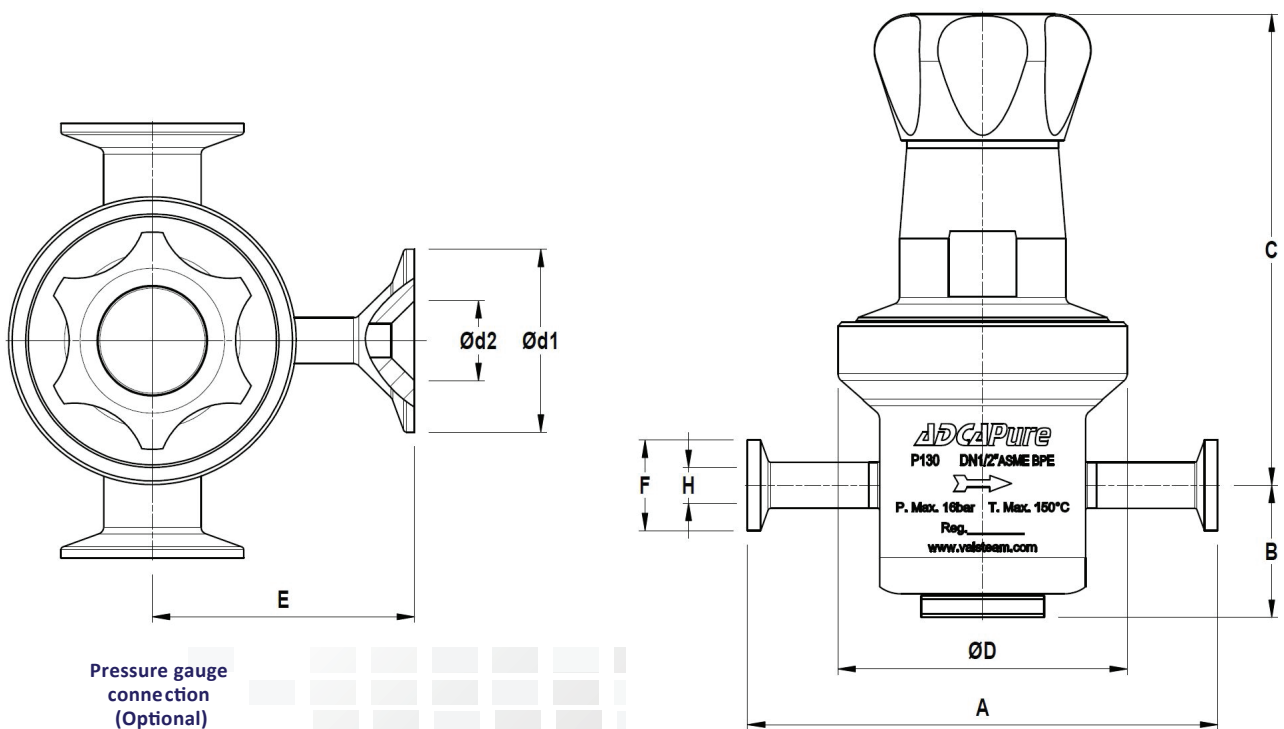

MATERIALS		
POS.	DESIGNATION	MATERIAL
1	Valve body	AISI316L / 1.4406
2	Cover	AISI316L / 1.4404
3	Seat cover	AISI316L / 1.4404
4	* O-ring	Viton / EPDM
5	*Piston	AISI316L / 1.4404
6	* Valve head	AISI316L / 1.4404 ; Viton ,PTFE
7	* Valve spring	AISI302 / 1.4300 (Polished)
9	Pusher disc	AISI 316L / 1.4404
10	* Lower diaphragm	PTFE
11	* Upper diaphragm	EPDM / VITON
12	Washer	AISI304 / 1.4301
13	Spring plate	AISI304 / 1.4301
14	Nut	St. steel A2-70
15	* Adjustment spring	AISI302 / 1.4300
16	Spring plate	AISI304 / 1.4301
17	Adjustment screw	AISI304 / 1.4301
18	Retaining washer	St. steel A2-70
19	Handwheel	AISI316L / 1.4404
19	Handwheel	Aluminium white painted
20	O-ring	EPDM
21	** O-ring	EPDM
22	Bearing	Corrosion res. Steel
23	Ext.bowed shaft ring	Stainless steel
24	Cover nut	Plastic
25	Captured vent ring	AISI 316L / 1.4404

* Available spare parts. ** On request

Remarks: FDA/USP Class VI seals certificate on request

All valves have a serial number. In case of non-standard valves this number must be supplied if spare parts are ordered.

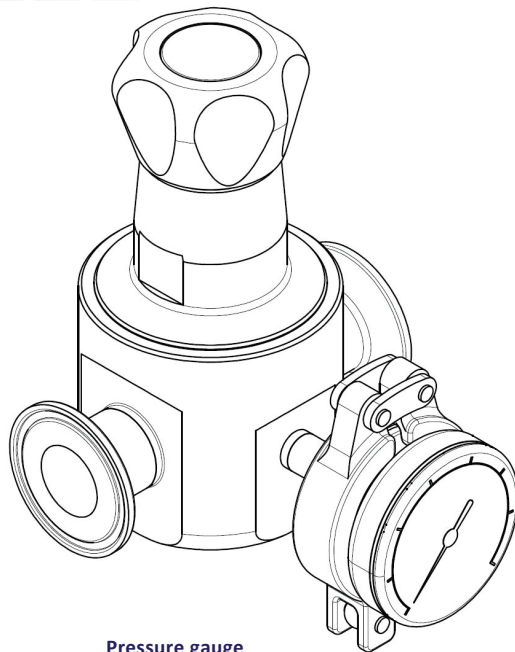
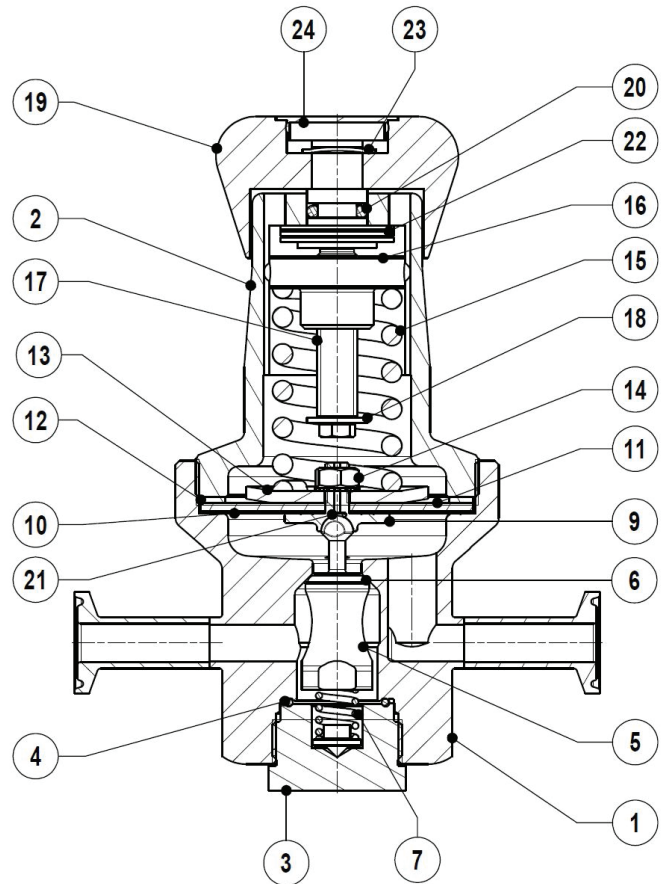

Pressure gauge connection (Optional)

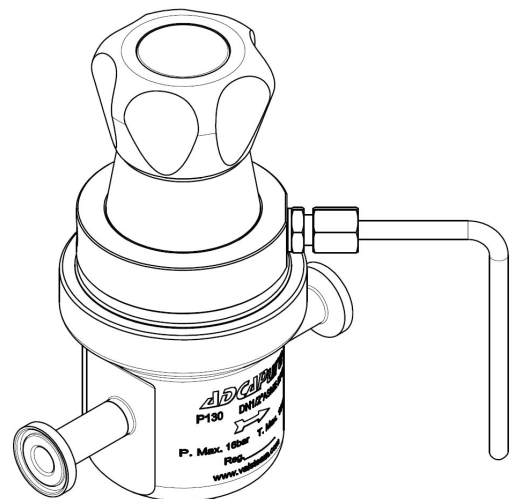
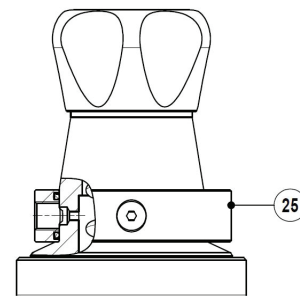

1/8" Captured vent and/or leakage connection (Optional)

Sealing Systems

19 Perissou St. Nea Chalkidona
P.O.14343 Athens Greece

Tel. 030 - 2108764820

e-mail: info@sealingsystems.gr

www.sealingsystems.gr